

Detachable Parallel Linear Gripper

HP04D Series

Standard Type

One-touch Finger Changer

Detachable bearing with one-touch operation.
New proposal for attachment replacement work.



Sold in three patterns: ①Main body + Bearing, ②Main body only and ③Bearing only

Excellent CENTERING Accuracy

◆ $\pm 0.07\text{mm}$ or less

Piping Port on 2 faces

Positioning Hole

- ◆ Rear Face
- ◆ Bottom Face

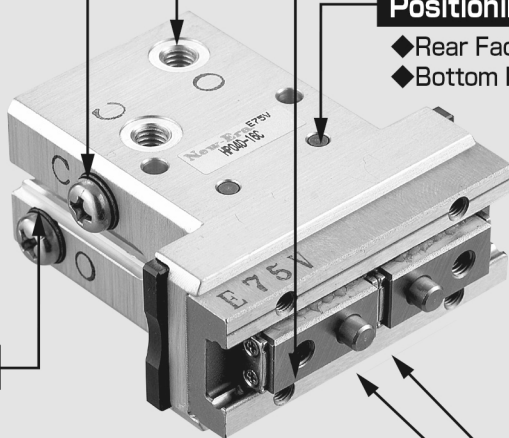

Sensor Switch Groove

Use of LINEAR GUIDE

- ◆ Withstand load, withstand moment (high rigidity)
- ◆ High accuracy (repeat accuracy: $\pm 0.01\text{ mm}$ or less)
- ◆ Gripping at a long point and overhang gripping are available.

Attachment 1

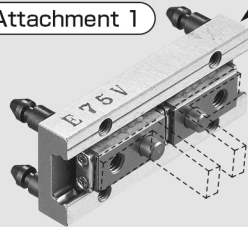

Attachment 2

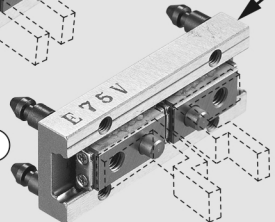

HP04D Series

Model Code No.

Main Body + Bearing Assy

HP04D - 10 C ※ HAE - ZE235 A 2

Series Name

Bore Size

10:10mm
16:16mm
20:20mm

Action Type

C : Double Acting

Quantity

1:1 Switch
2:2 Switches

Lead Wire Length

A:1m
B:3m



●Gripper Adaptor Type
No Code: No Gripper Adaptor

HAE



HFE
HFE.L: Large Diameter Type
(φ16 only)



●Detailed specifications→P.105

●Switch Type No Code: No Switch

ZE135

ES13

2 Wire System Solid State Switch, Straight Type

ZE235

ES23

2 Wire System Solid State Switch, L-shaped

ZE155

ES(P)15

3 Wire System Solid State Switch, Straight Type

ZE255

ES(P)25

3 Wire System Solid State Switch, L-shaped



●Switch details→P.521~528

Main Body Assy

DB - HP04D - 10 C ※ HAE - ZE235 A 2

Main Body Assy

Series Name

Bore Size

10:10mm
16:16mm
20:20mm

Action Type

C : Double Acting

Quantity

1:1 Switch
2:2 Switches

Lead Wire Length

A:1m
B:3m



●Gripper Adaptor Type
No Code: No Gripper Adaptor

HAE



HFE
HFE.L: Large Diameter Type
(φ16 only)



●Detailed specifications→P.105

●Switch Type No Code: No Switch

ZE135

ES13

2 Wire System Solid State Switch, Straight Type

ZE235

ES23

2 Wire System Solid State Switch, L-shaped

ZE155

ES(P)15

3 Wire System Solid State Switch, Straight Type

ZE255

ES(P)25

3 Wire System Solid State Switch, L-shaped



●Switch details→P.521~528

Bearing Assy

DG - HP04D - 10

Bearing Assy

Series Name

Bore Size

10:10mm
16:16mm
20:20mm



Specifications

	10	16	20
Action Type	Double Acting		
Bearing Attachment/Removal Method	Manual		
Bore Size [mm]	φ10	φ16	φ20
Fluid	Air		
Working Pressure Range [MPa]	0.2~0.7	0.12~0.7	0.1~0.7
Proof Pressure [MPa]	1.05		
Maximum Operating Cycle [Cycle/min]	120		
Operating Temperature [°C]	0~60 (No Freezing)		
Lubrication	Not Required (Required for sliding parts of the machine)		
Pipe Bore	M3×0.5	M5×0.8	
Applicable Switch	ZE, ES Type (Solid State Switch)		
Centering Accuracy [mm]	±0.07		
Repeat Accuracy [mm]	±0.01		
Repeat Attachment/Removal Accuracy [mm] (Centering Accuracy)	0.05		

Action Type	Model	Bore Size [mm]	Minimum Operating Pressure [MPa]	Opening/Closing Stroke [mm]	Gripping Force*1 [N]		Outside Dimensions (T x W x L) [mm]	Product Mass [g]
					Close	Open		
Double Acting	HP04D-10C	10	0.2	6.5	10	15.6	20×41×49	80
	HP04D-16C	16	0.12	10	26	39	25×56×56	160
	HP04D-20C	20	0.1	14	45	60	32×68×67	320

※1) The indicated grip force is measured at the intermediate position of the opening/closing stroke. It is an effective value when the grip point L is 30 mm and the pressure is 0.5 MPa.

See List of Effective Grip Forces (Page 59) for details.

The unit of the allowable load FX is N. The unit of the allowable moments MA, MB and MC is Nm.

When this product is used with an extremely short stroke, it may work badly because of the lack of oil of the guide.

HP04D Series

Internal Structure Diagram

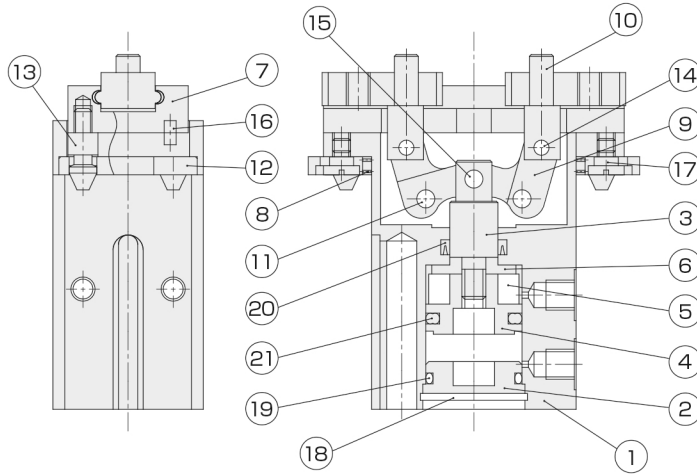

Parts List

NO	Name	Material	NO	Name	Material
1	Main Body	Aluminum Alloy	12	Stopper	Stainless Steel
2	Head Cover	Aluminum Alloy	13	Pin	Stainless Steel
3	Piston Rod	Stainless Steel	14	Press Fit Pin	Carbon Tool Steel
4	Piston	Aluminum Alloy	15	Press Fit Pin	Carbon Tool Steel
5	Magnet	Resin	16	Press Fit Pin	Carbon Tool Steel
6	Pressure Cover	Aluminum Alloy	17	Slotted Head Machine Screw	Stainless Steel
7	Bearing	Bearing Steel	18	Hole Locating Snap Ring	Carbon Tool Steel
8	Spring	Piano Wire	19	O Ring	NBR
9	Action Lever	Carbon Steel	20	Rod Packing	NBR
10	Knuckle	Stainless Steel	21	Piston Packing	NBR
11	Fulcrum Pin	Carbon Tool Steel			

Allowable Load and Allowable Moment

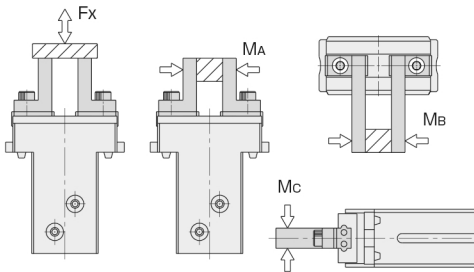

Load and Moment	Fx [N]	MA [N·m]	Mb [N·m]	Mc [N·m]
Model				
HP04D-10	50	0.4	0.4	0.4
HP04D-16	120	1	1	1
HP04D-20	200	1.5	1.5	1.5

Effective Gripping Force

Closing Force (Double Acting Type)

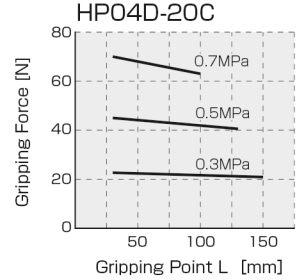
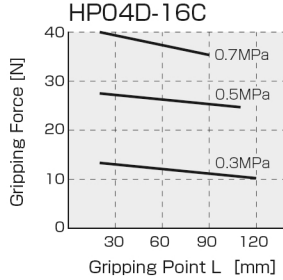
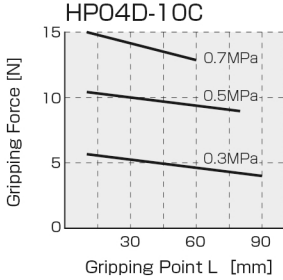

Opening Force (Double Acting Type)

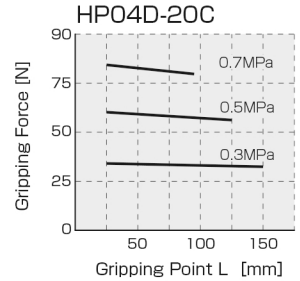
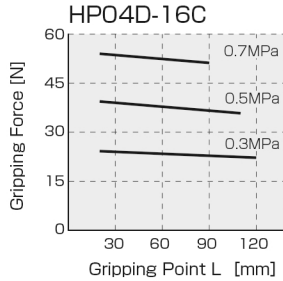
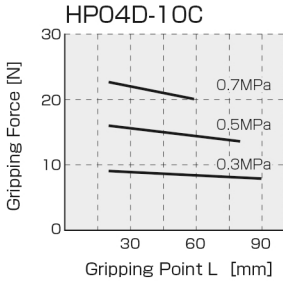

■ Gripping Point Limit Range

HP04D-10

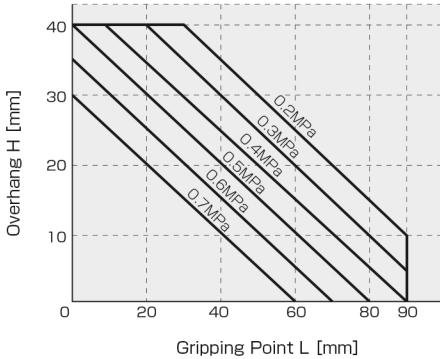

HP04D-16

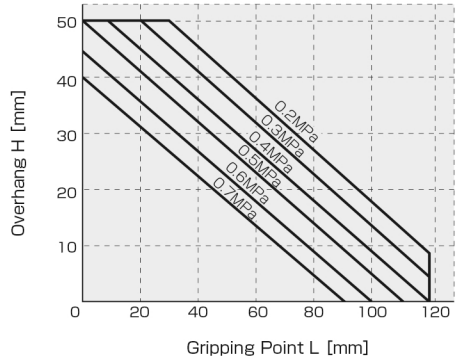

HP04D-20

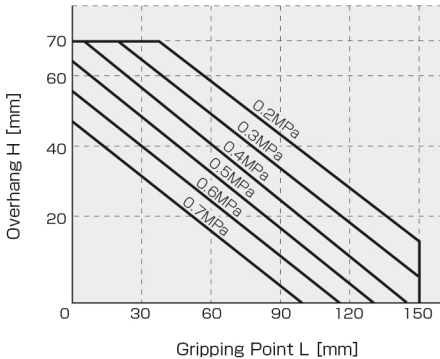
**● Mounting of the attachment**

L (distance gripping point) and H (overhang distance) of the attachment to be mounted to the lever shall be within the range specified in the above drawing (Gripping point limit range). If they exceed the limit range, excess moment will be applied to the guide, causing troubles that have a bad influence on the life and accuracy (e.g. finger backlash). Even if they are within the limit range, the attachment shall be as small and light as possible.

● Guide for selecting a model for the workpiece weight

It shall be 5 to 10% of the effective gripping force or any value less than that although it differs depending on the coefficient of friction between the attachment and the workpiece and the shape. It shall be greater than that when great acceleration or impact is applied during workpiece transportation.

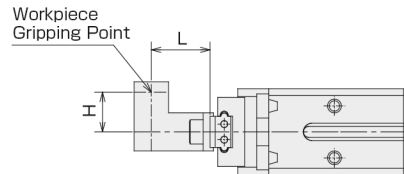

Bearing Attachment/Removal Method

Removal Method (Example)

STEP.1

Air Exhaust

The opening (closing) port exhausts air that is supplied to the inside of the cylinder.

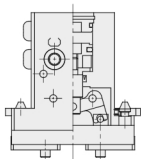

STEP.2

Attachment/Removal Position

Move the lever to the specified position by external force or the like. This makes the action lever vertical.

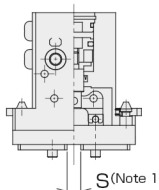

STEP.3

Decoupling

Push the stopper by external force or the like. This makes the hardware free. (Note 2)

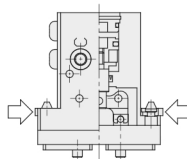

STEP.4

Removal

Remove the bearing.

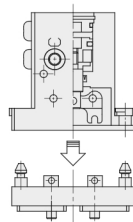

Note 1)

The dimension of the attachment/removal position S differs depending on the product size. See the following table.

Model	HP04D-10	HP04D-16	HP04D-20
S	3	5.6	8

Note 2) If you make the pin free when the lever is attached in the vertically downward direction, the bearing may fall due to the own weight of the lever. So be fully careful to make it free.

Attachment Method (Example)

STEP.1

Attachment/Removal Position

Keep the bearing separated.

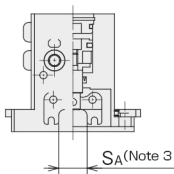

STEP.2

Stand-by for Attachment

Push the stopper by external force or the like.

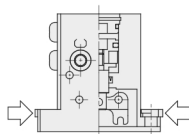

STEP.3

Attachment

Attach the bearing while keeping the stopper inserted and the levers are in the SA state.

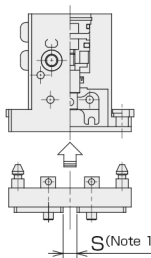

STEP.4

Retention

The bearing is retained by releasing the stopper.

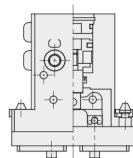

Note 3)

When the action lever is not in the specified position, adjust the action lever position with reference to the dimension SA in the table below.

Model	HP04D-10	HP04D-16	HP04D-20
SA	7	11.6	16

Part Names

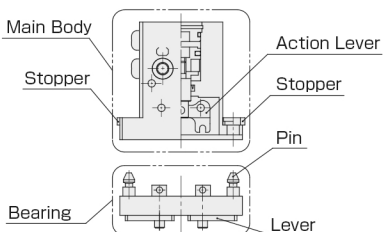

HP04D Series

Main Body Mounting Method

Mounting Example

- 1** When the through-hole of the main body is used
(Switch not attachable in this case)

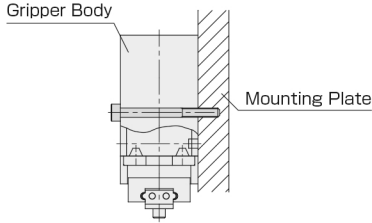

Model	Bolt to be Used	Maximum Tightening Torque[N·m]
φ10	M3×0.5	0.59
φ16	M3×0.5	0.59
φ20	M4×0.7	1.37

- 2** When the screw on the back face of the main body is used

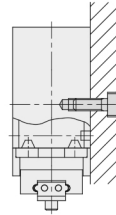

Model	Bolt to be Used	Maximum Tightening Torque[N·m]
φ10	M4×0.7	1.37
φ16	M4×0.7	1.37
φ20	M5×0.8	2.84

- 3** When the screw on the side of the main body is used

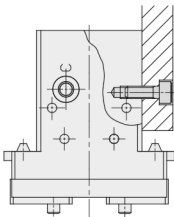

Model	Bolt to be Used	Maximum Tightening Torque[N·m]
φ10	M3×0.5	0.59
φ16	M4×0.7	1.37
φ20	M5×0.8	2.84

- 4** When the screw on the bottom face of the main body is used
(Only φ8 requires a space such as a relief because the switch protrudes.)

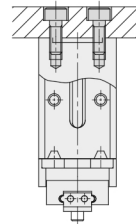

Model	Bolt to be Used	Maximum Tightening Torque[N·m]
φ10	M3×0.5	0.59
φ16	M4×0.7	1.37
φ20	M5×0.8	2.84

Outline Dimensional Drawing of Gripper Adaptor

HAE Type

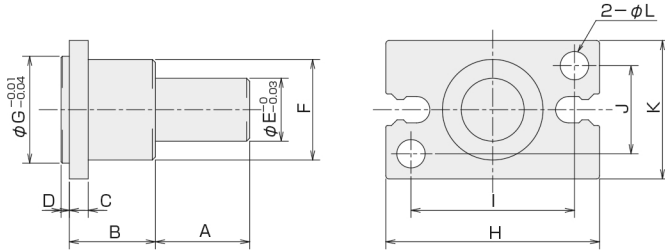

Type	Code	A	B	C	D	E	F	G	H	I	J	K	L	Ancillary Bolt (x2)	Product Mass [g] (Including Bolts)
HAE-10		15	15	3	1.3	10	11	11	23	17	10	16	3.4	M3×0.5×8 ^L	11
HAE-16		15	15	3	1.3	10	16	17	34	26	14	22	4.5	M4×0.7×10 ^L	20
HAE-20		15	15	3	1.3	10	18	21	45	35	16	26	5.5	M5×0.8×10 ^L	28

HFE形

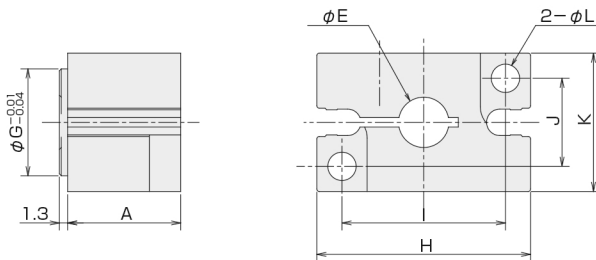

Type	Code	A	E	G	H	I	J	K	L	Ancillary Bolt (x3)		Product Mass [g] (Including Bolts)
										Gripper Mounting (x2)	Adapter Fixing (x1)	
HFE-10		15	6	11	23	17	10	16	3.4	M3×0.5×16 ^L	M3×0.5×12 ^L	14
HFE-16		18	8	17	34	26	14	22	4.5	M4×0.7×20 ^L	M4×0.7×16 ^L	35
HFE-16L		18	10	17	34	26	14	22	4.5	M4×0.7×20 ^L	M4×0.7×16 ^L	33
HFE-20		19	13	21	45	35	16	26	5.5	M5×0.8×20 ^L	M5×0.8×20 ^L	55

HP04D Series

Attachment Design Method

Example of Attachment Design

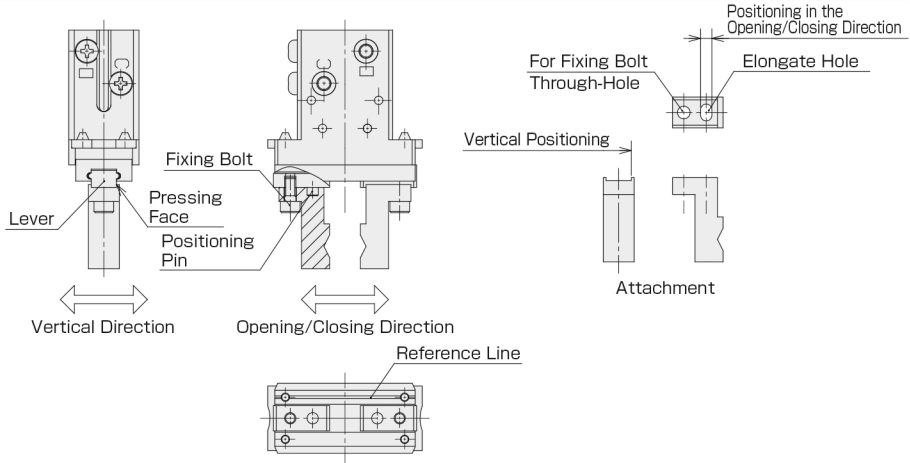

Attachment Mounting Method

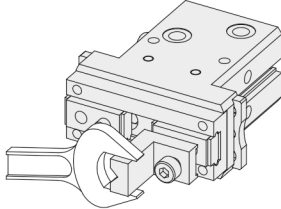

When you mount the attachment, hold the attachment with a spanner or the like to remove load to the lever.

Model	Bolt to be Used	Maximum Tightening Torque[N·m]
φ10	M3×0.5	1.14
φ16	M4×0.7	2.7
φ20	M5×0.8	5.4

Positioning Hole

Positioning Hole for Mounting Examples 1 and 2 (P.104)

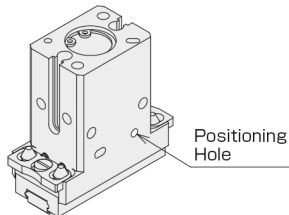

Model	Positioning Hole
φ10	φ2.5 ^{+0.02} depth 2.5
φ16	φ3 ^{+0.02} depth 3
φ20	φ4 ^{+0.02} depth 3.5

Positioning Hole for Mounting Examples 4 (P.104)

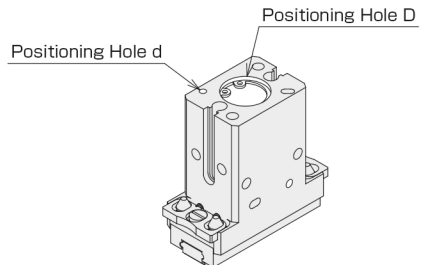

Model	Positioning Hole D	Positioning Hole d
φ10	φ11 ^{+0.05} depth 1.5	φ2 ^{+0.04} depth 2
φ16	φ17 ^{+0.05} depth 1.5	φ2.5 ^{+0.04} depth 3
φ20	φ21 ^{+0.05} depth 1.5	φ3 ^{+0.04} depth 3